



ROGGEERS

For the Perfection of Football Fundamentals™

PRODUCT INFORMATION PACKET

PRODUCT NAME: COACH'S COMMAND TOWER

PART NUMBER: 360168

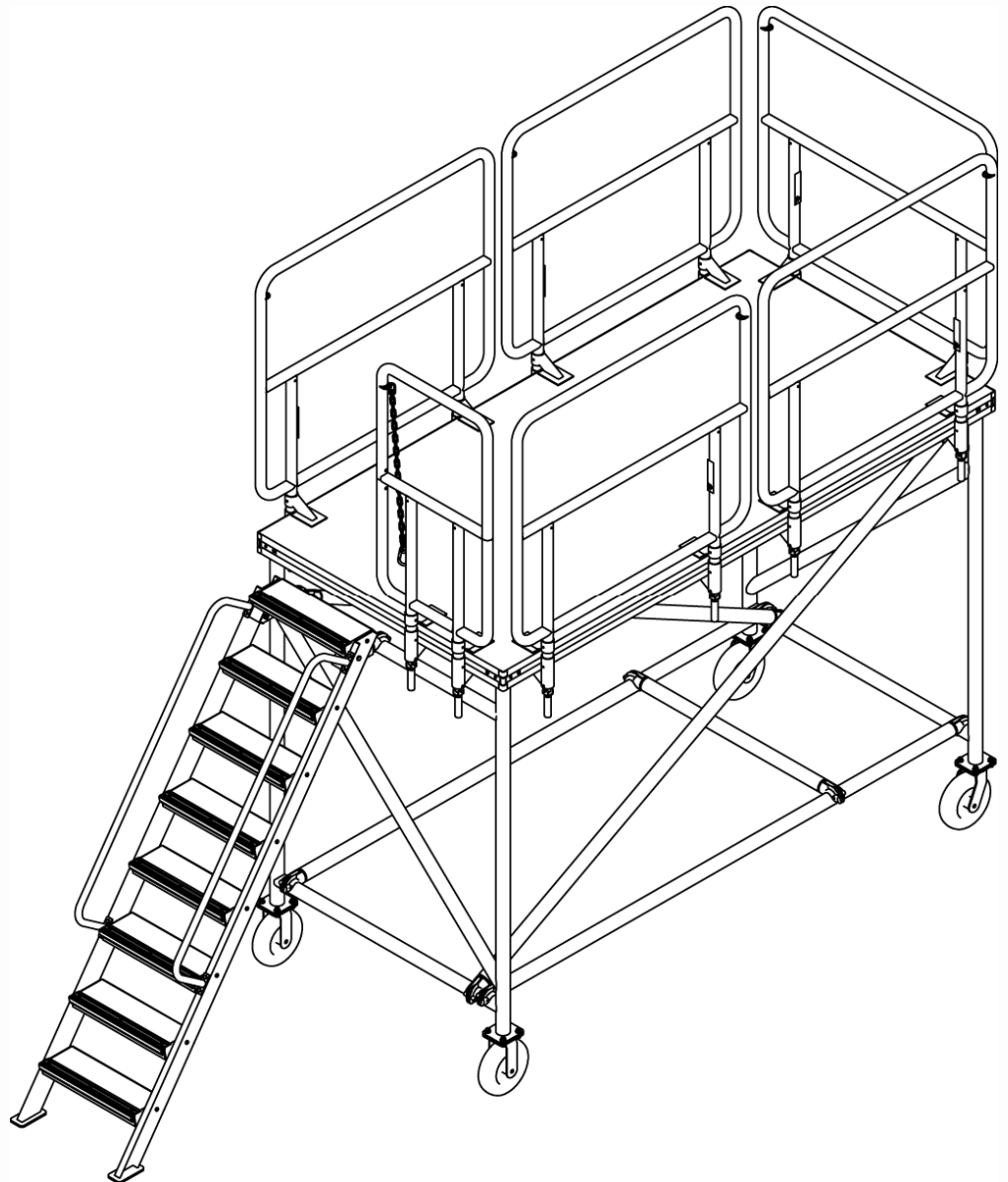

KEEP INFORMATION PACKET FOR FUTURE REFERENCE

Table of Contents

- Introduction.....1
- General Safety Rules.....2
- Symbols.....3
- Technical Specifications.....4
- Assembly Instructions.....5
- Maintenance.....10
- Customer Service Information.....10

Introduction

The Rogers Athletic Coach's Command Tower has been designed and manufactured with safety, performance and dependability as top priorities, making it easy to operate and maintain.

The care you give your Coach's Command Tower will greatly determine your satisfaction with its performance and service life. Careful study of this manual is encouraged to obtain a thorough understanding of your new Coach's Command Tower and its functions and maintenance.

If your manual becomes lost or destroyed, Rogers Athletic will gladly provide you with a new copy. Should you require additional information or assistance, please feel free to contact us at 1-800-438-4499.

BECAUSE Rogers Athletic CORPORATION MAINTAINS AN ONGOING PROGRAM OF PRODUCT DEVELOPMENT AND IMPROVEMENT, WE RESERVE THE RIGHT TO MAKE IMPROVEMENTS IN DESIGN OR CHANGES IN SPECIFICATIONS WITHOUT INCURRING ANY OBLIGATIONS TO INSTALL THEM ON UNITS PREVIOUSLY SOLD.

General Safety Rules



WARNING!



READ AND UNDERSTAND ALL INSTRUCTIONS

Failure to follow all instructions listed below may result in serious personal injury.

SAVE THESE INSTRUCTIONS

- **SET BRAKES ON THE Coach's Command Tower WHILE IN USE AND WHEN LEFT UNATTENDED!**
- **Stay clear of all pinch points.** Keep hands away from pinch points.
- **Use on level surface.**
- **Do not haul Coach's Command Tower at speeds exceeding 5 mph.** Hauling at excessive speed may cause the tower to lose control, causing an accident or serious injury.
- **The Coach's Command Tower is for Off Road use only.** The tower is intended to be used at practice/game fields.
- **Do not ride on the Coach's Command Tower.** The Coach's Command Tower is intended for stationary use only. Failure to abide by this rule can cause serious personal injury.
- **Do not climb on the Coach's Command Tower.** Access to the platform should only be accomplished by use of the provided stair system.
- **Do not exceed platform weight limit of 700 pounds.**
- **Save these instructions.** Refer to them frequently and use them to instruct others who may use the Coach's Command Tower.
- **Read the Product Information Packet.** Failure to read the information packet is considered a misuse of this equipment.
- **Become familiar with all caution and warning decals affixed to the field equipment before use.**
- **Never cover or deface caution/warning labels.**
- **Make sure all rail clamps are secure before every use.**

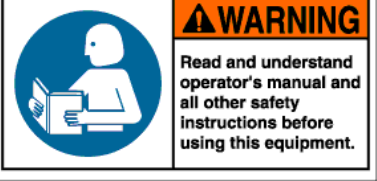
Symbols

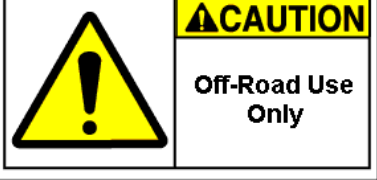
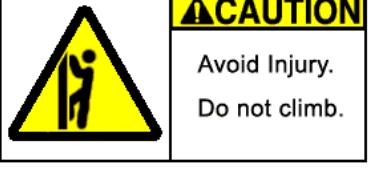
	<p>Safety Alert: Precautions that involve your safety</p>
	<p>Read The Operator's Manual: To reduce risk of injury, user must read and understand operator's manual before using this product</p>
	<p>Pinch Point Warning Label: Failure to keep hands away from pinch points will result in personal injury</p>
	<p>For Off-Road Use Only Warning Label: Field equipment is not intended or designated for roadway travel. Do not exceed 5 mph!</p>
	<p>Do Not Climb Warning Label: To reduce risk of injury, do not climb on field equipment. No acrobatics from platform.</p>

ROGERS ATHLETIC FIELD EQUIPMENT SPECIFICATIONS

Coach's Command Tower

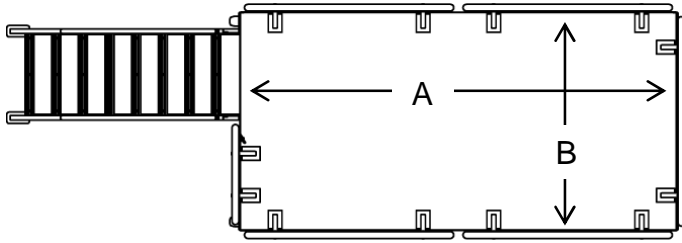

Weight:	537 lbs
Dim A:	8 ft
Dim B:	4 ft
Dim C:	42 in
Dim D:	6 ft

- 4'x 8' platform area
- 42" rail height for safety and confidence
- 6' platform height
- 6 ½" stair tread depth for quick, sure footing
- Stairs stow inside tower frame
- 8" foam filled wheels roll easily over terrain and won't go flat

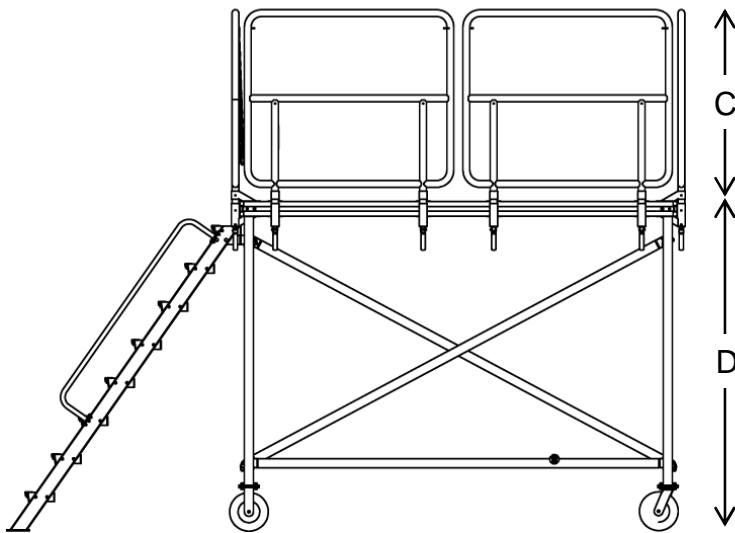

Construction, Finish and Hardware

- Constructed of ASTM specified steel and aluminum
- Non – marking foam filled casters
- Zinc-plated hardware
- Baked on powder coat finish

Assembly Instructions

1

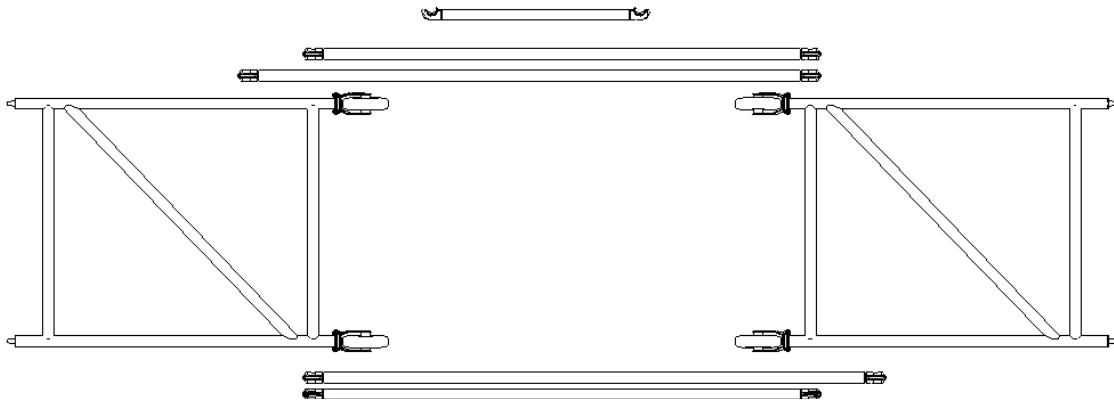

Note: Assembly will require at least two people.

Lay out the understructure as shown. Having parts in approximate layout will be a great help during assembly.

2

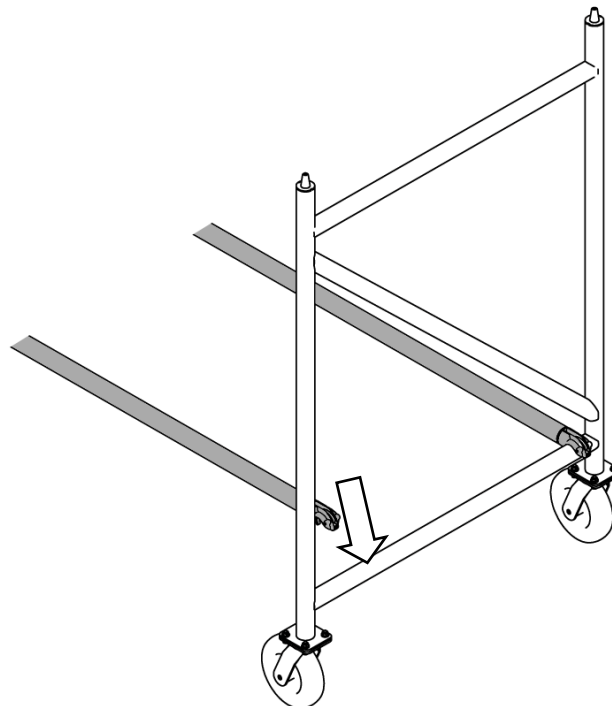

With the casters locked, raise the H-Sections. While holding the H-section upright, place the two shorter connector bars on the lower horizontal tube as shown.

3

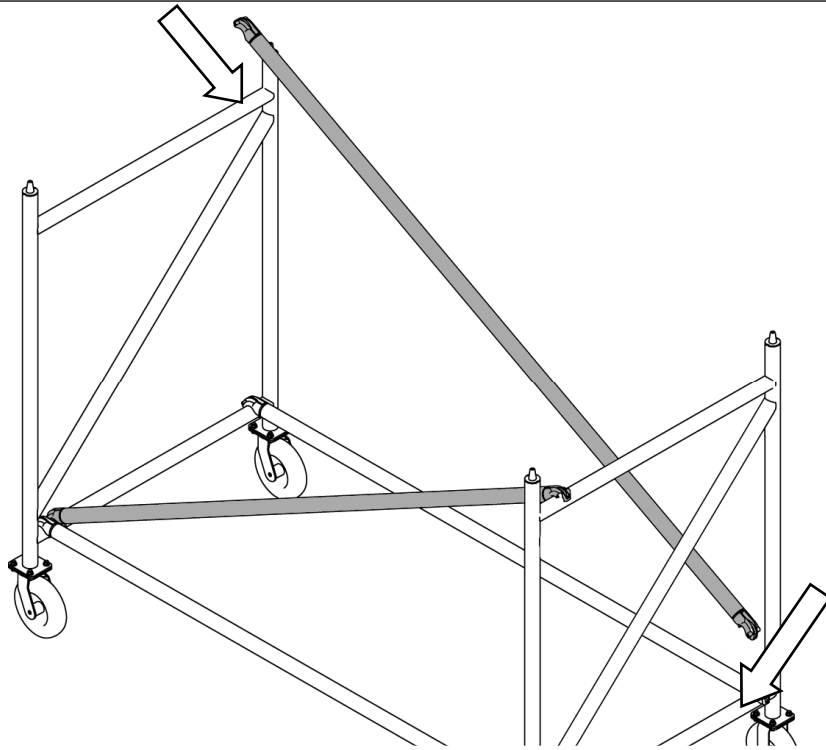

Next, attach longer connector bars to a lower, and an upper horizontal tube as shown. Make sure all frame locks are locked.

4

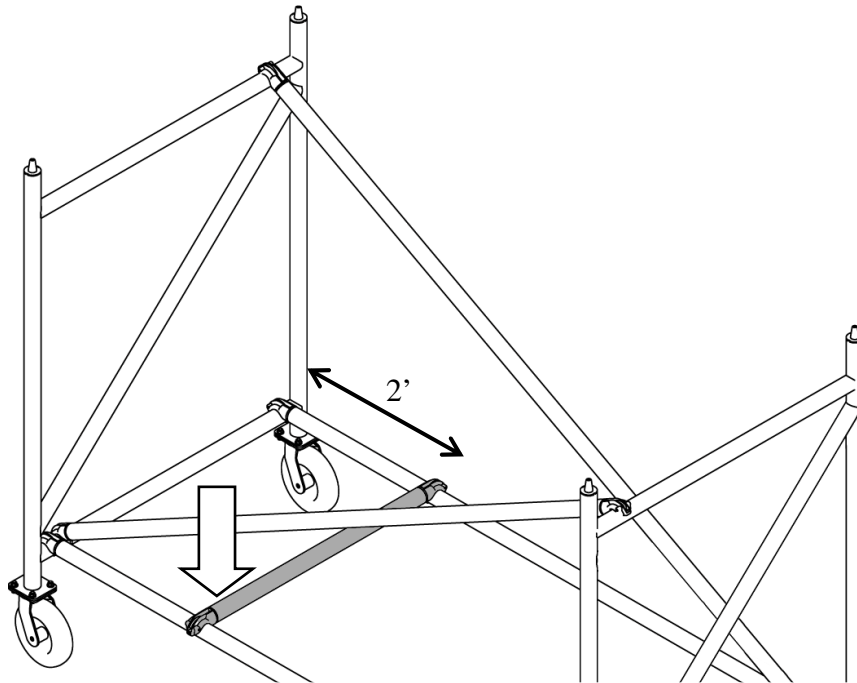

Place the shortest connector between the two horizontal connectors, 2 ft. from one end.

5

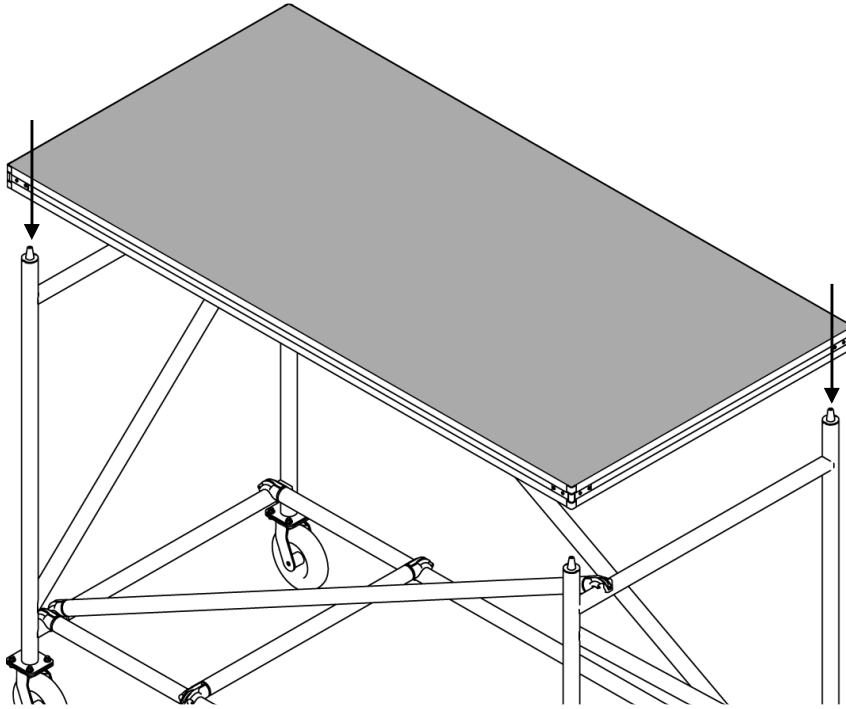

Place deck onto conical nodes. Assure the deck is fully placed on all four nodes.

6

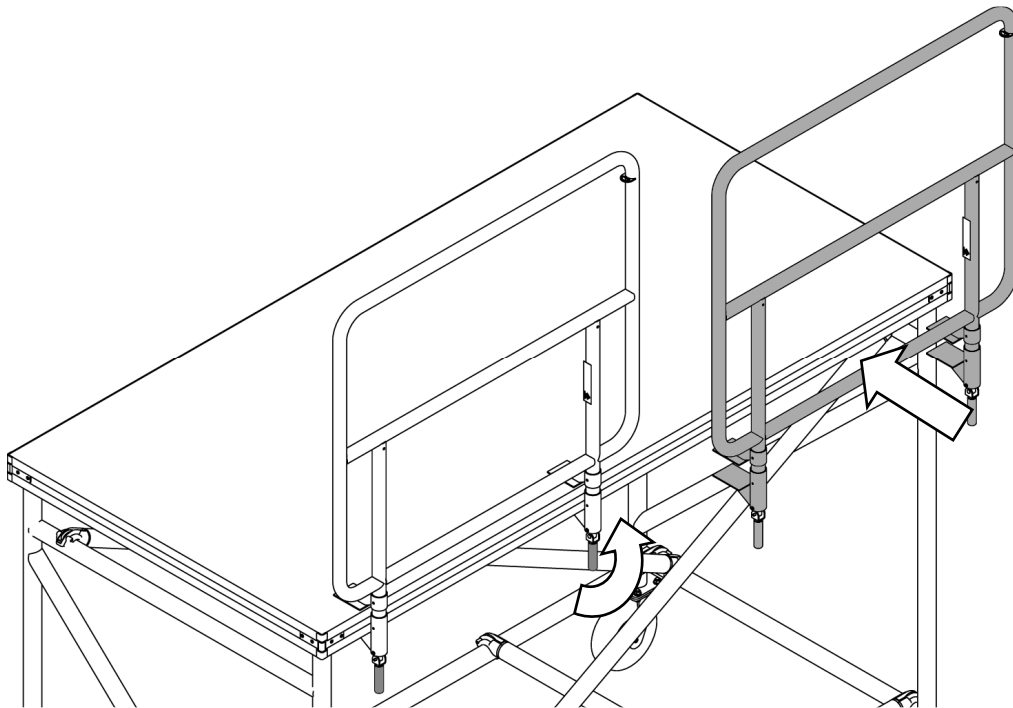

Place rails on deck, to secure rails, turn handles clockwise. Make sure someone is holding the rail until BOTH handles are tightened, and rail is fully secured to the deck. Repeat until all 6 rails are secured.

7

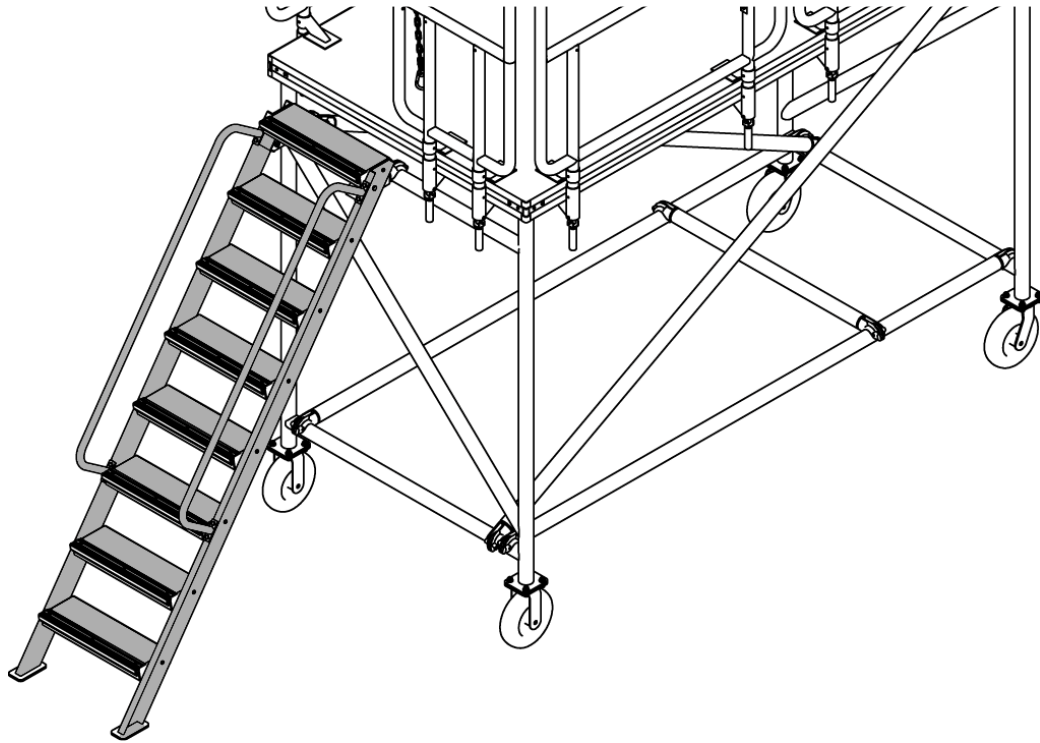

Place stair assembly on the top horizontal tube of the h-section containing the 2' rail. Make sure the Frame Locks are fully secured.

8

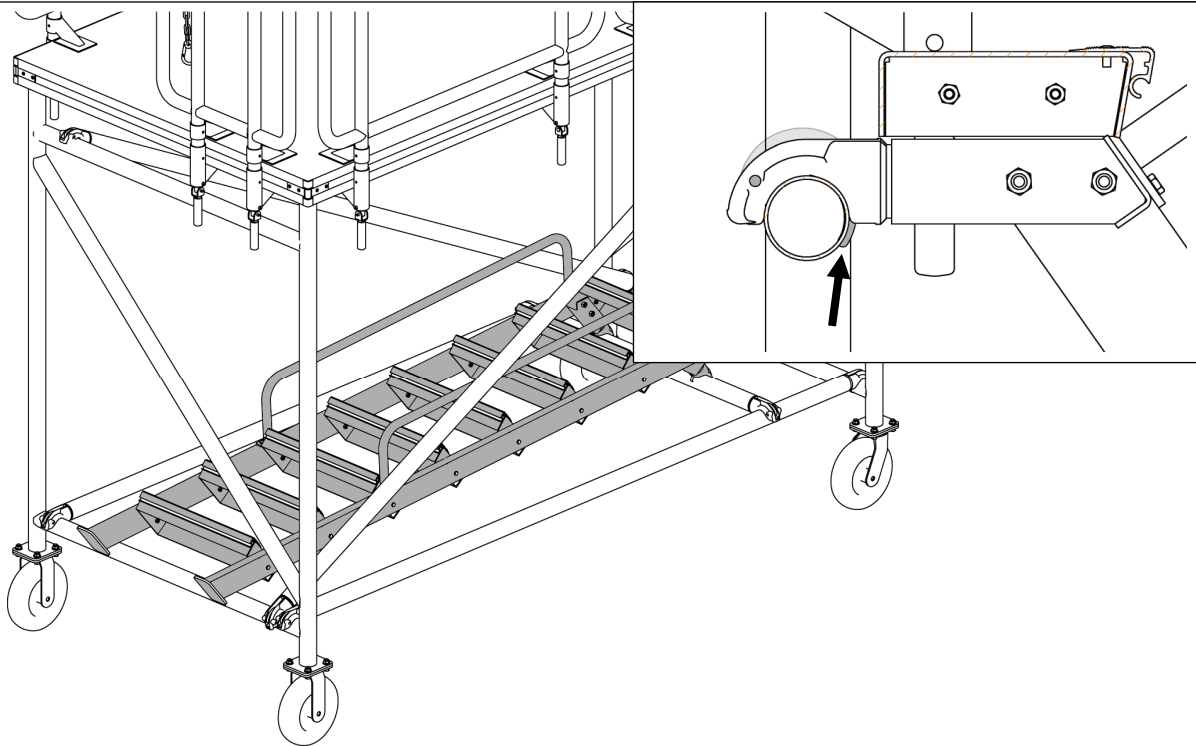

Stow the stairs by clipping them to the short crossbar on the base of the tower frame. To release frame locks for stowing stairs or disassembly, push the finger of the lock upward and lift the lock off the tube.

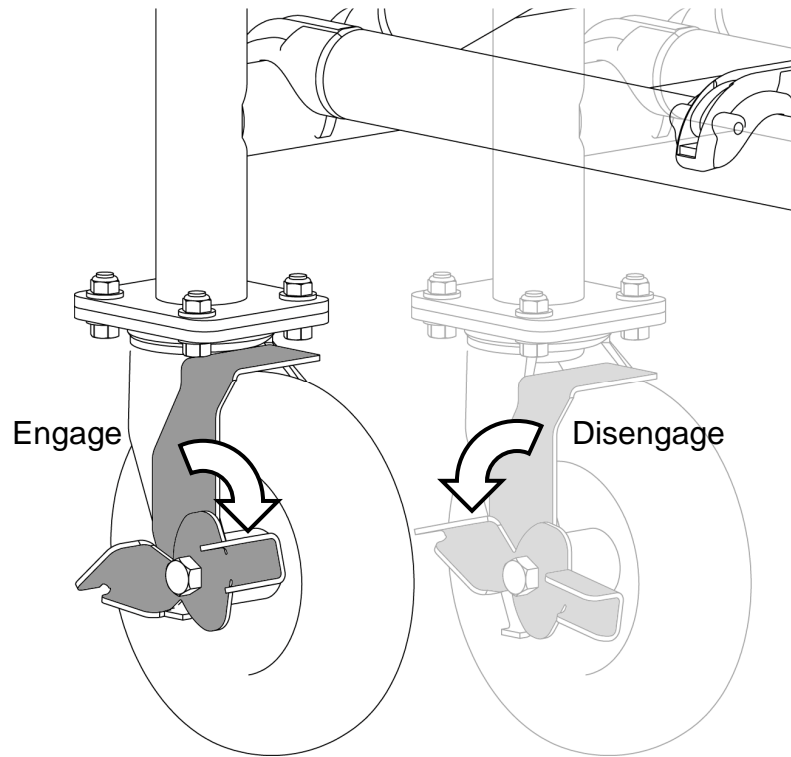

CASTER BRAKES MUST BE ENGAGED BEFORE STANDING ON THE Coach's Command Tower!

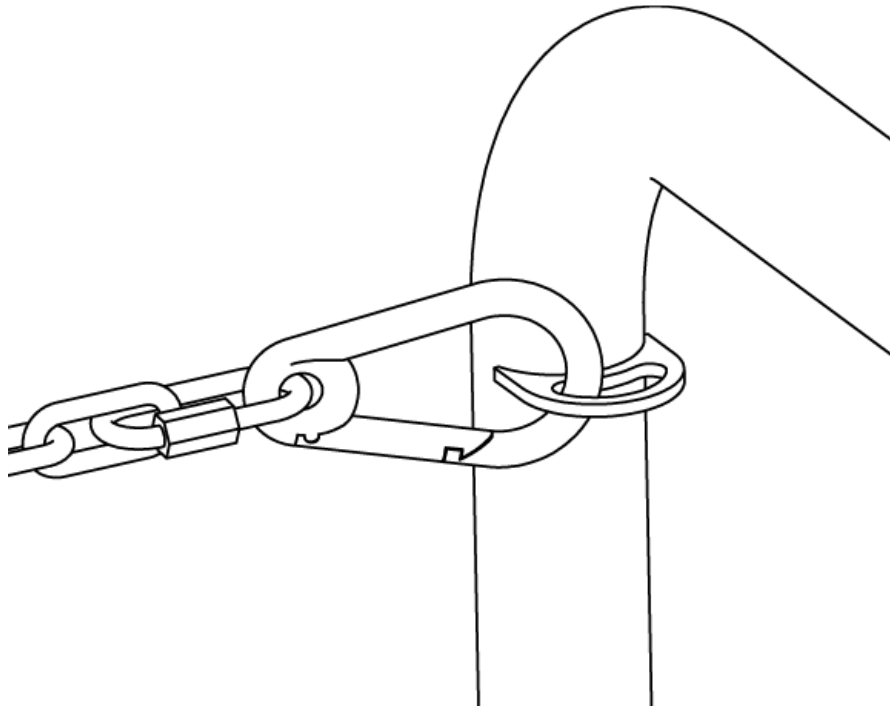

CLIP THE SAFETY CHAIN WHILE THE Coach's Command Tower IS IN USE. BUT BE SURE CHAIN IS *DISENGAGED* WHEN DISASSEMBLING THE TOWER.

Maintenance



WARNING!

Read and Understand All Maintenance Procedures

Failure to follow all procedures listed below may cause serious injury and a decrease in the equipments functional existence.

- **Frequently check to see that all fasteners are properly engaged.**
- **Touch up paint can be used to cover any scratches or blemishes sustained through use.**
- **Replace any damaged equipment with genuine Rogers's Athletic parts.** Failure to do so may result in unsafe equipment and/or personal injury.

Customer Service

For parts or service contact Rogers Athletic Company. When ordering parts be sure to provide all relevant information available including the name and part number of the equipment purchased. This information is located on the cover of this product information package. Hours of phone service are Monday thru Friday from 8:00 a.m. to 5:00 p.m. Eastern Standard Time. Customers can phone toll-free at (800) 248-0270 or mail:

Rogers Athletic Company
3760 N. Ludington Drive
Farwell, MI 48622

Rogers Athletic Company
3760 N. Ludington Drive
Farwell, MI 48622
www.rogersathletic.com
(989) 386-2950
(800) 248-0270
Fax toll free (888) 549-9659